

Project 1

NE555 Single LED Flasher

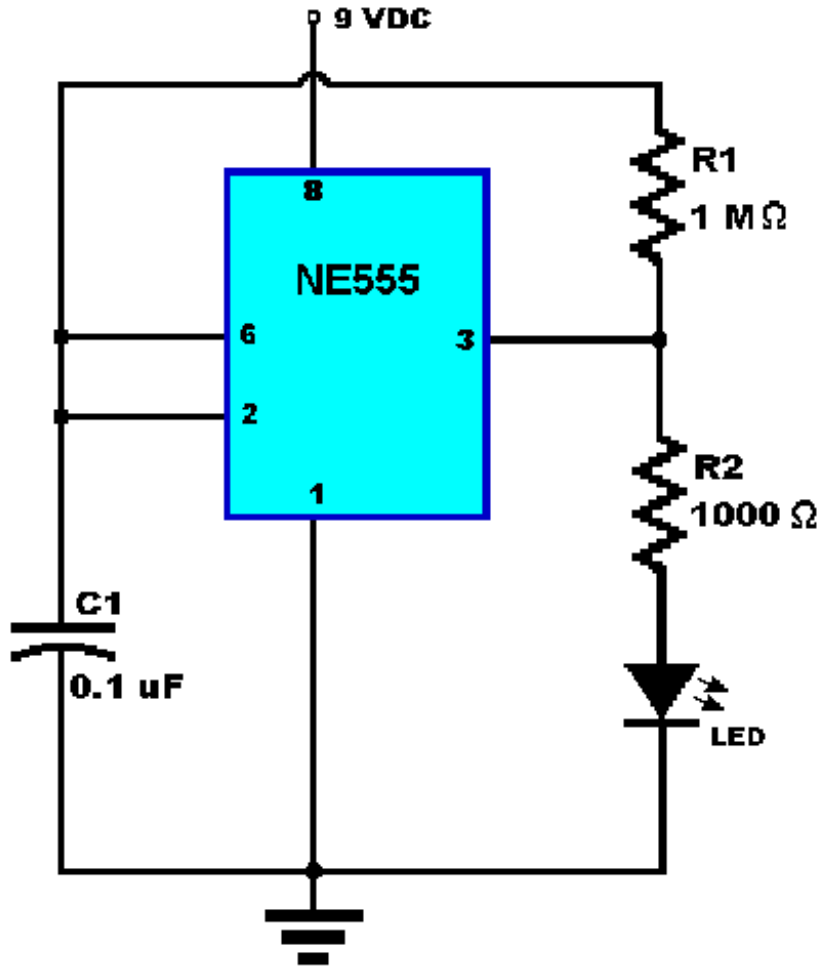

Explore the values of R1 and C1 to control the flash rate of the LED. What is the function of R2?

Project 2

Transistor LED Flasher

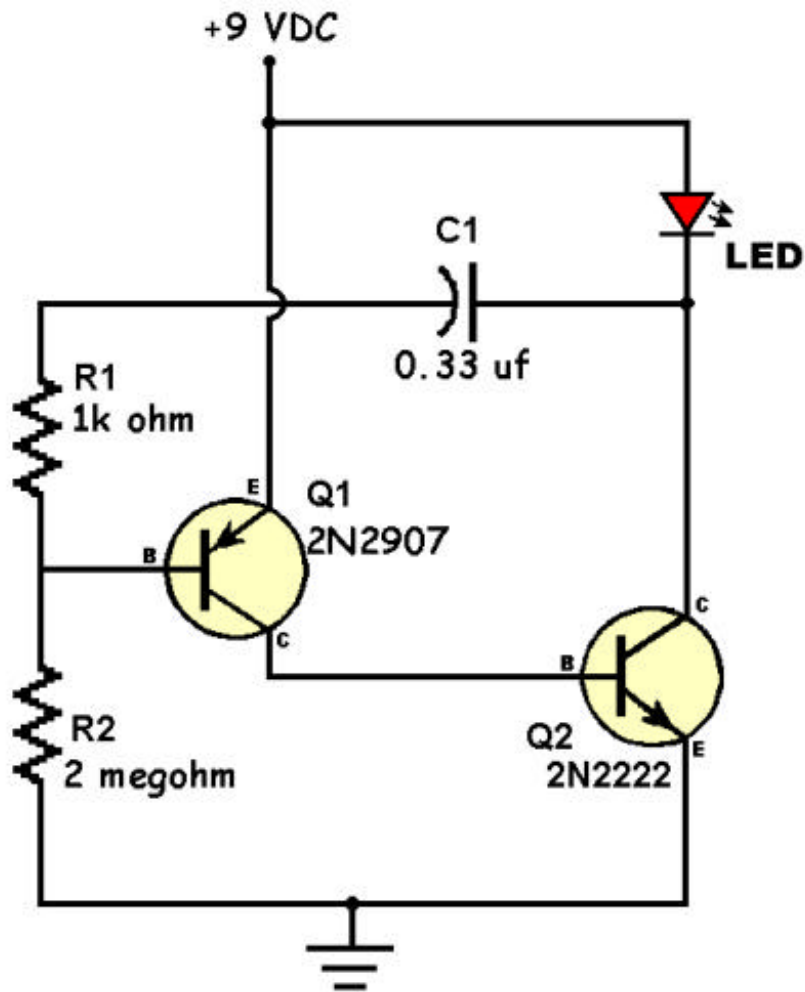

Explore the RC time constant of C1 and R2 to control the flash rate of the LED. Observe the correct wiring of the transistors to avoid “smoke.”

Project 3

NE555 Sound Generator

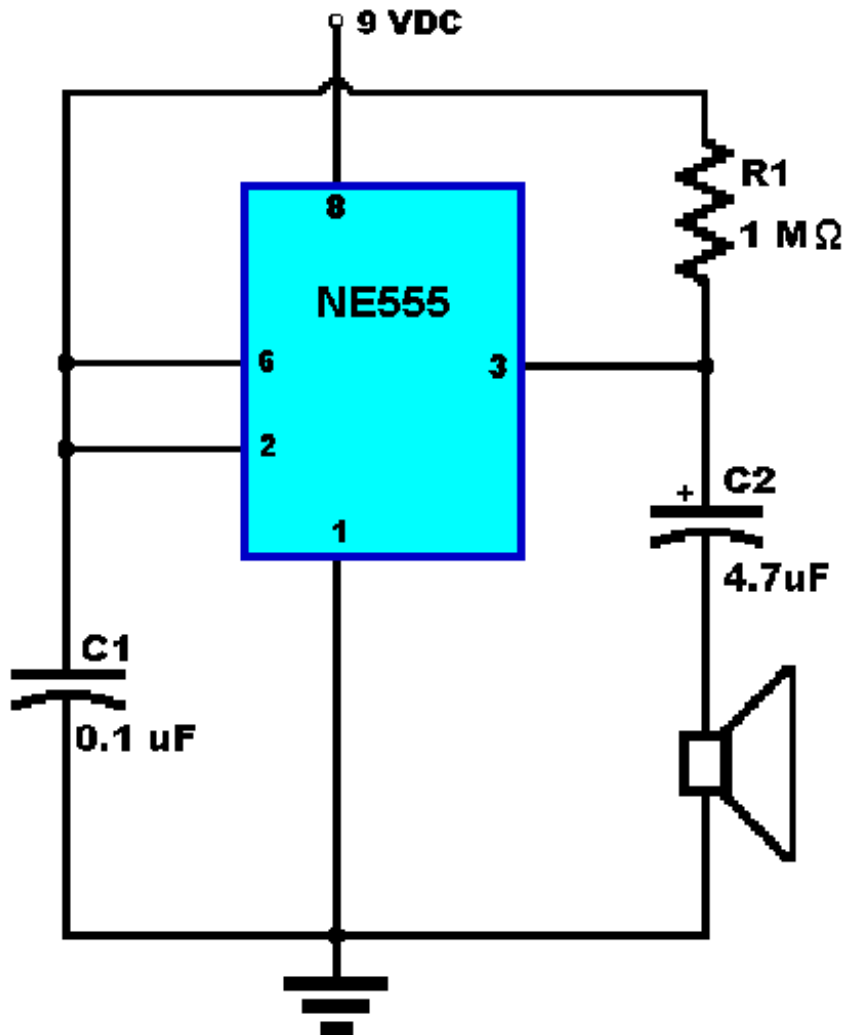

Experiment with the time constant of C1 and R1 to produce different sounds.

Project 4

Dual Transistor LED Flasher

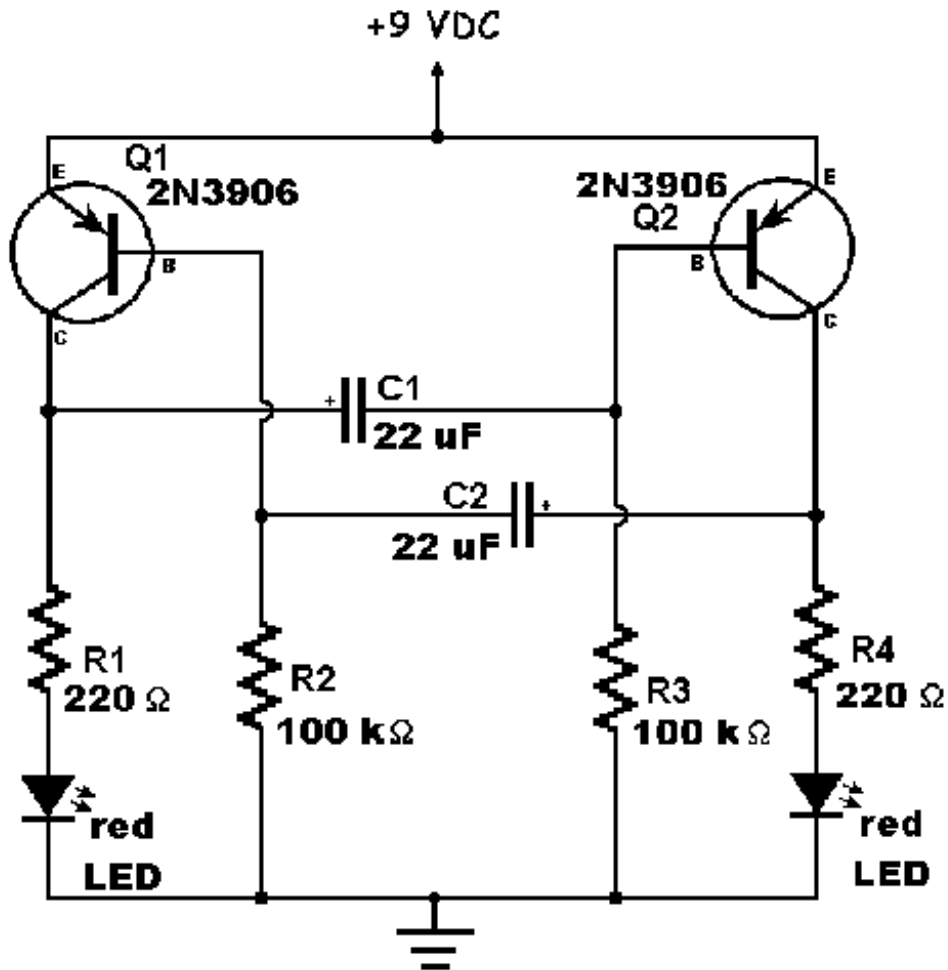

This is a visually appealing circuit. Experiment with the time constant of C1/C2 and R2/R3 for the flash rate and flash duration. R1 and R4 are current limiting resistors for the LEDs.

Project 5

NE555 Alternating LED Flasher

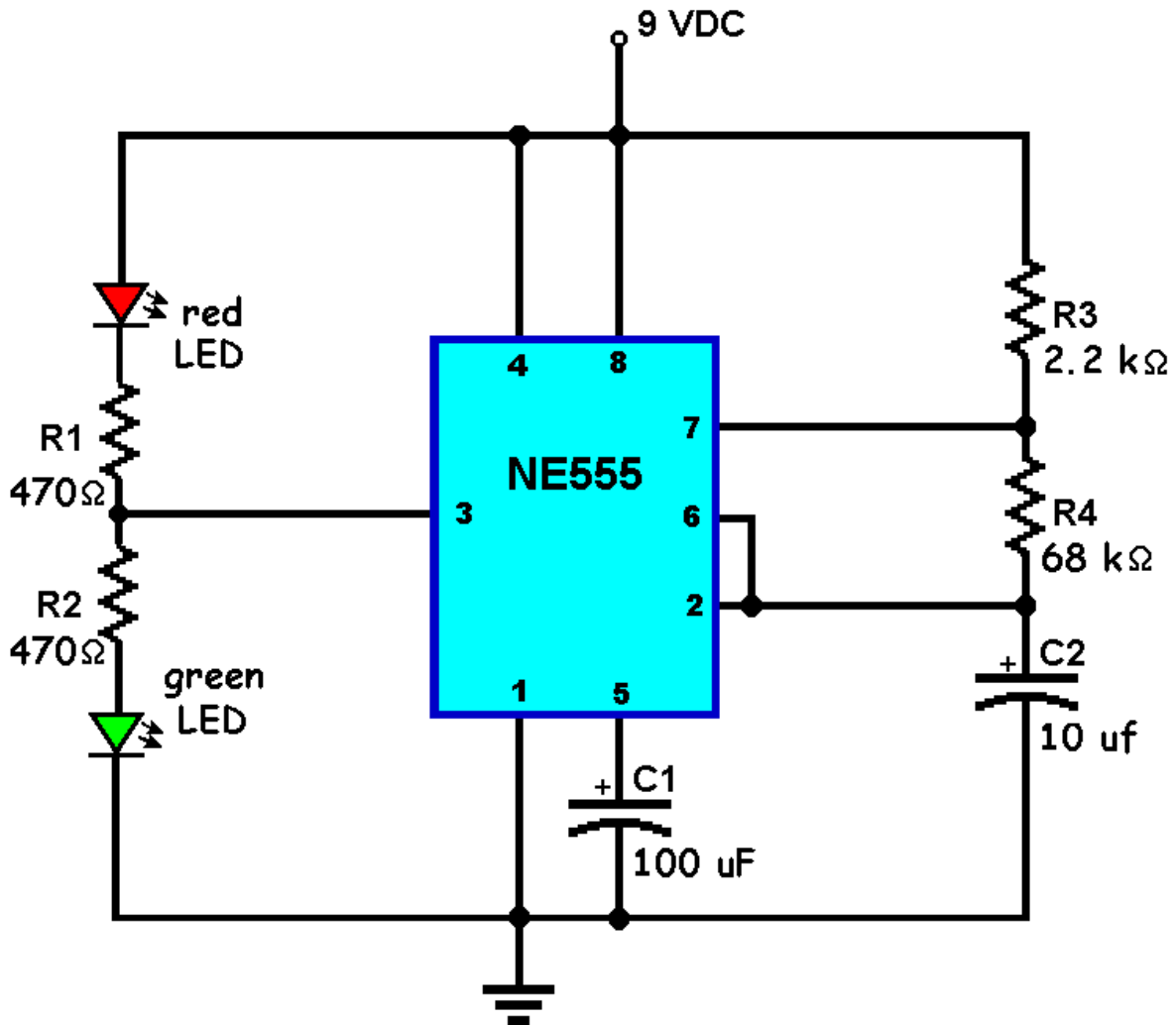

Experiment with the time constant of C1, C2, R3, and R4 to control the flash rate and flash duration of the LEDs. What is the function of R1 and R2?

Project 6

Transistor Multiple Alternating LED Flasher

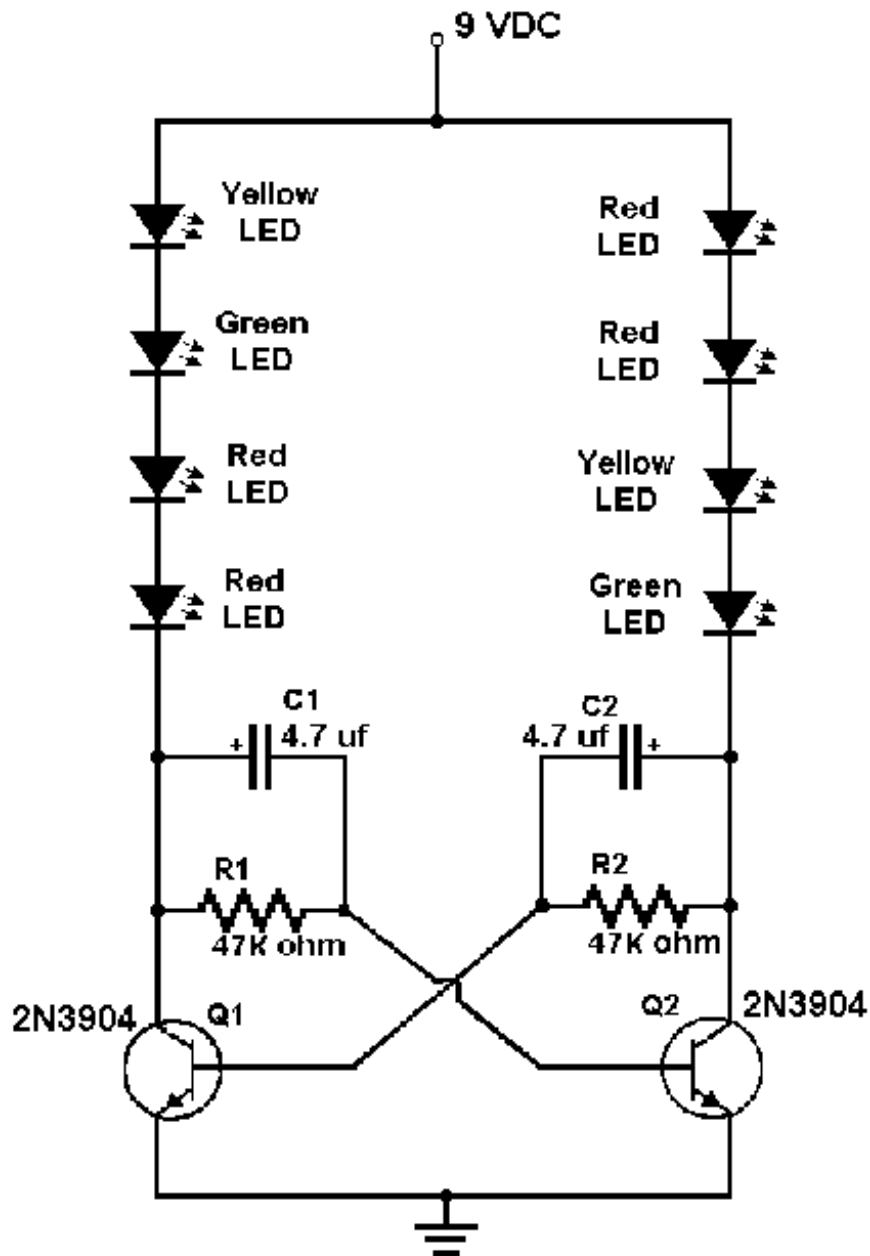

This is a very visually appealing project. Experiment with the C1/C2 and R1/R2 time constant. Can you make one side flash different from the other side?

Cautions: Observe the correct wiring of the transistors or know the location of the nearest Radio Shack. If the battery has low voltage only one of the LEDs strings will light.

Project 7

Siren

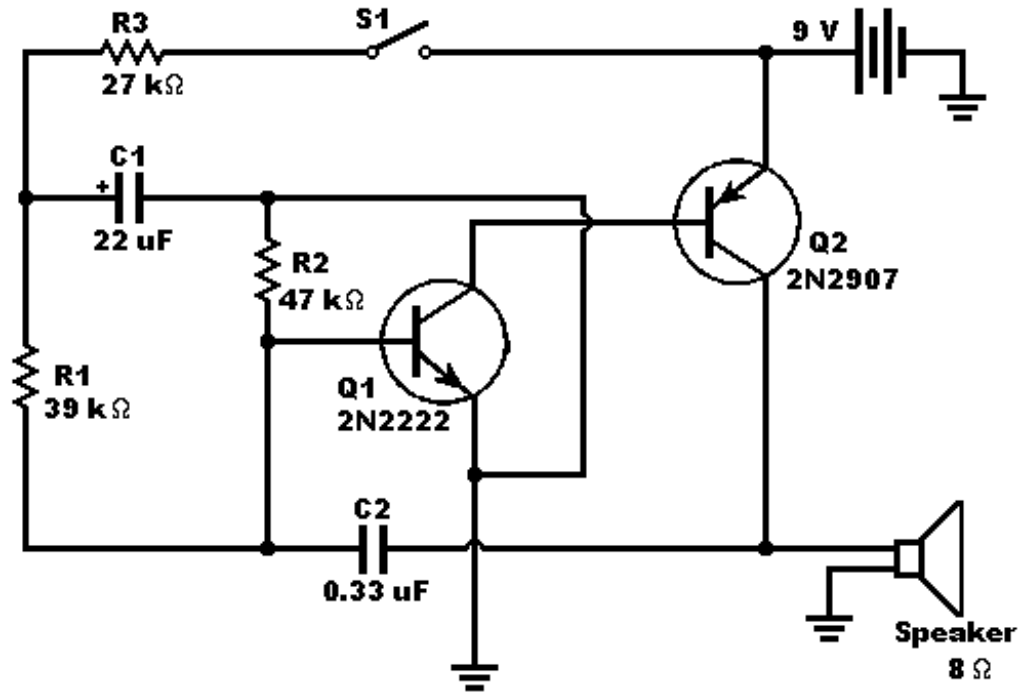

This is a fun circuit but wire it correctly to avoid smoking the transistors. Experiment with C1, C2, R1, and R2 for the pitch and frequency of the siren.

Project 8

Transistor Metronome

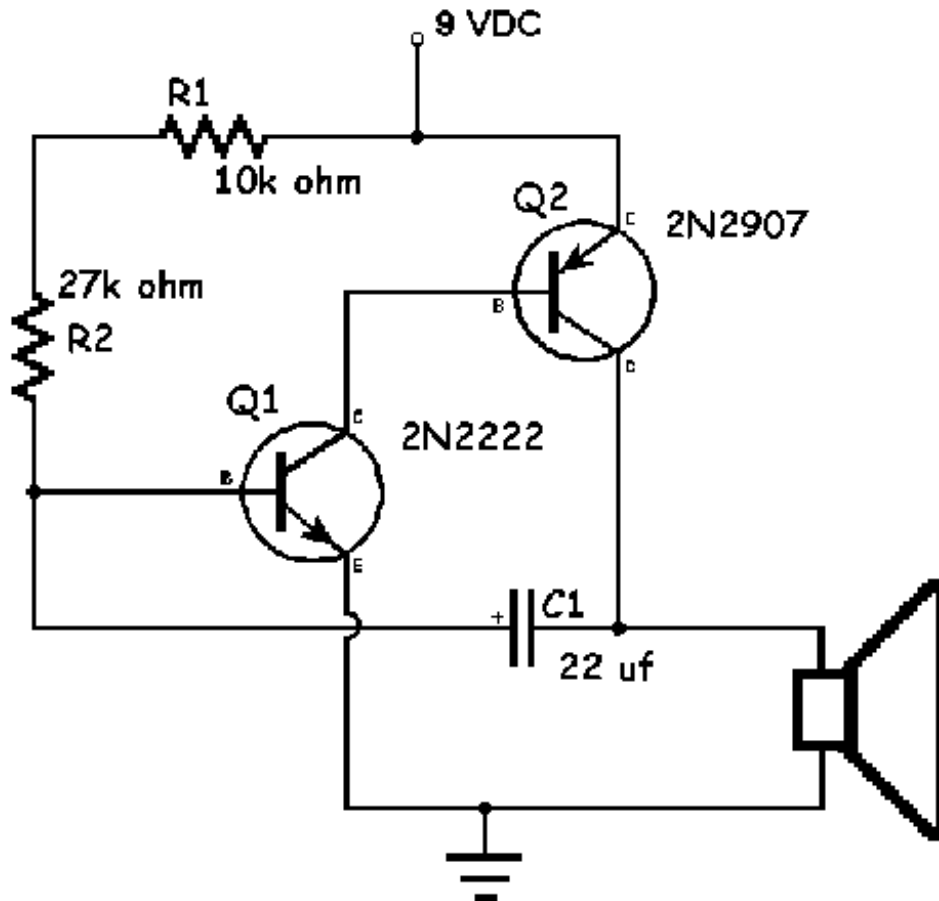

The frequency of this transistor metronome is controlled by the time constant of R2 and C1. Experiment with these values to change the frequency of the “Toc.”

Caution! Easy to build but incorrect wiring of this circuit **WILL** blow out the transistors!

Project 9

Music Maker

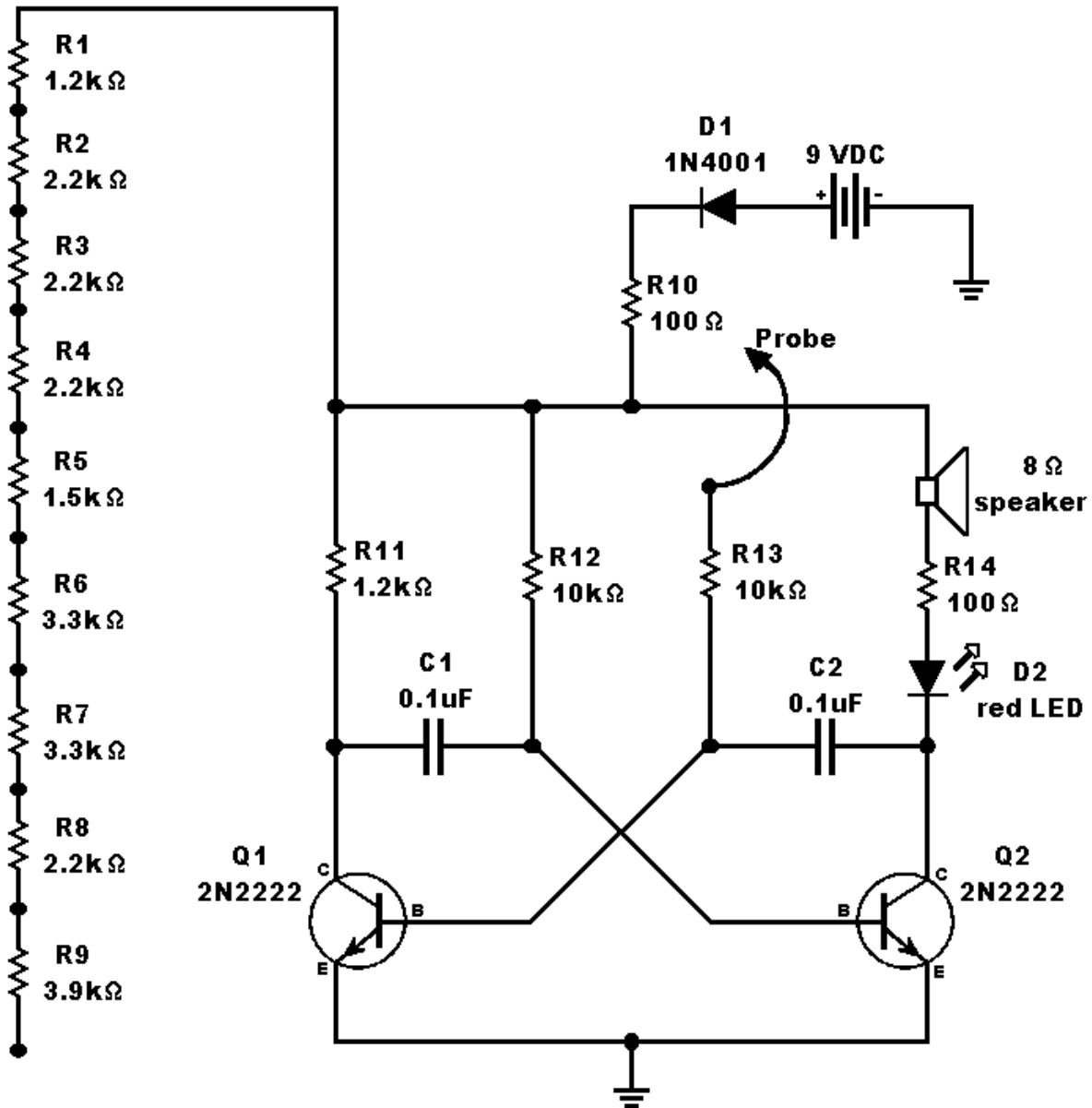

Note: Touch the probe wire to any of the junctions between R1 to R9 to produce various musical tones.

This circuit provides a wide range of musical notes. The time constant of C1/C2 and R1-R9 produce the tones. Experiment how the range of tones could be shifted up or down.

Project 10

NE555 Toy Organ

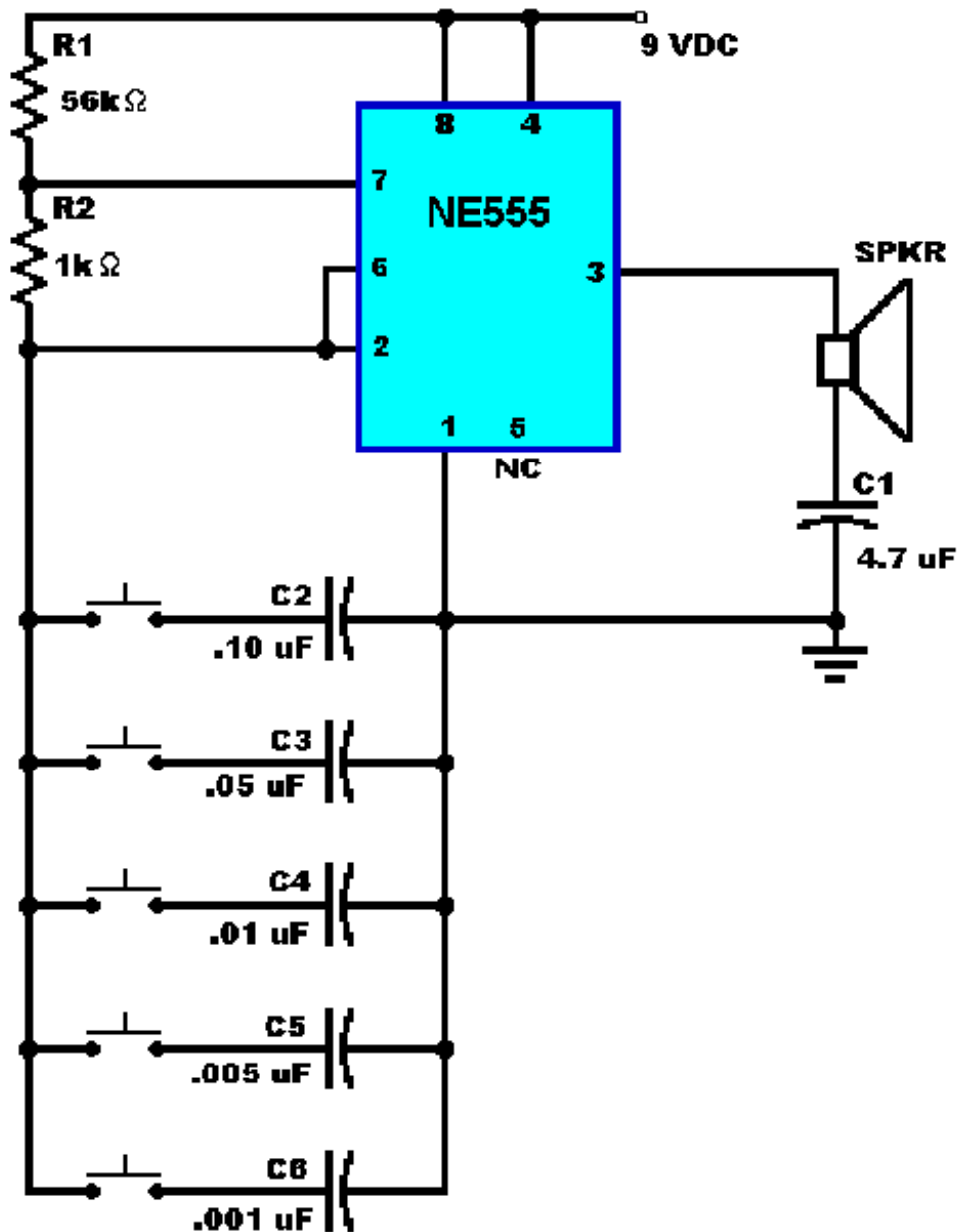

This circuit will produce a variety of musical notes. The exact values of C2 through C6 are not available so either series or parallel capacitors to get close to the indicated value.

Project 11

NE555 Metronome

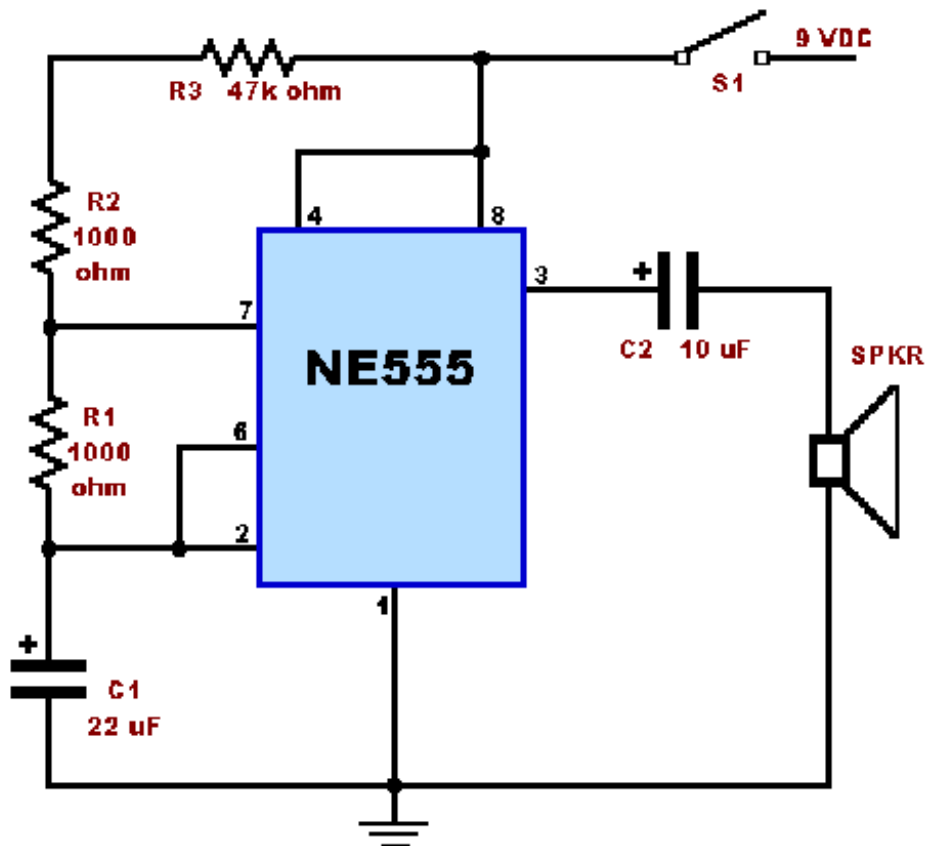

This circuit produces a “Tic-tic” sound. Experiment with C1 and R1 to adjust the duration between the “tic-tic.”

Project 12

Code Practice Oscillator

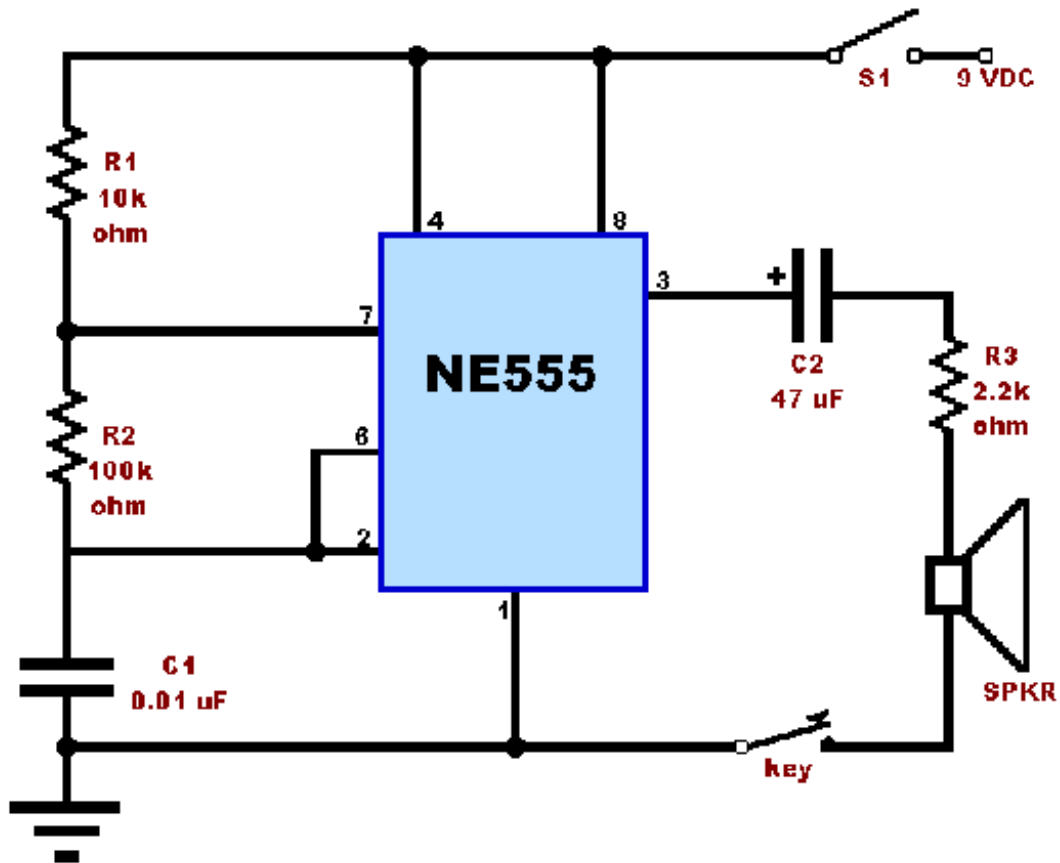

This circuit is designed to produce a tone similar to a Morse code signal you would hear from a short wave radio. Experiment with C1 and R2 time constant for changes in the tone. If you build this circuit, learn a few Morse code characters.

The volume of this circuit is very low. Which resistor can be eliminated to fix this? What is the intended function of that resistor?

Project 13

HEE - HAW Tone generator

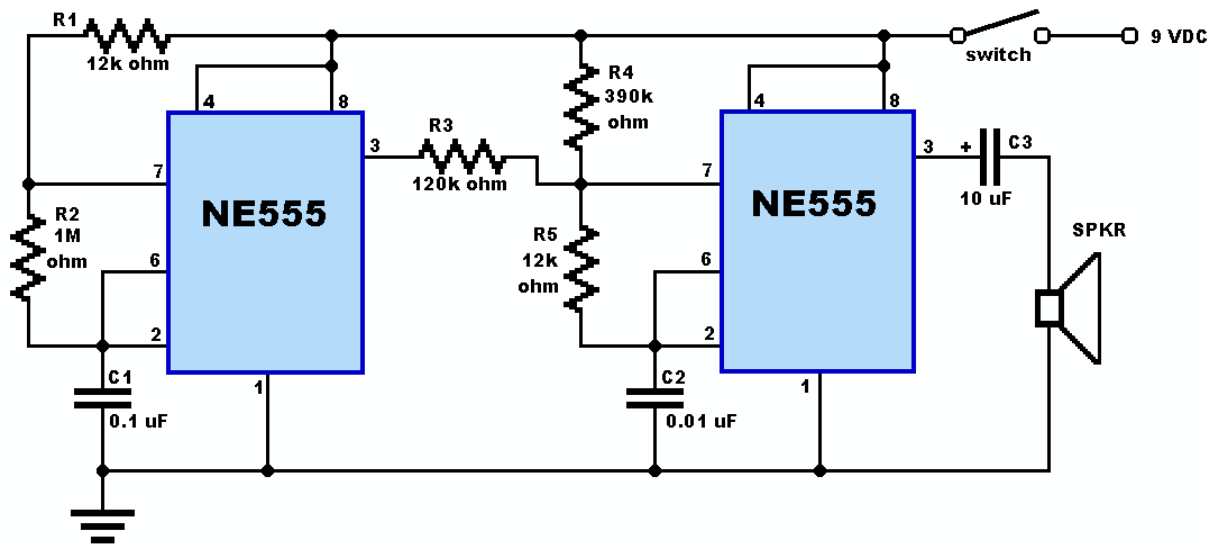

This circuit is supposed to produce a “Hee-Haw” tone. It has not been tested but examination indicates it should work if built according to the above schematic diagram. Good luck and have fun!

Project 14

NE555 Siren

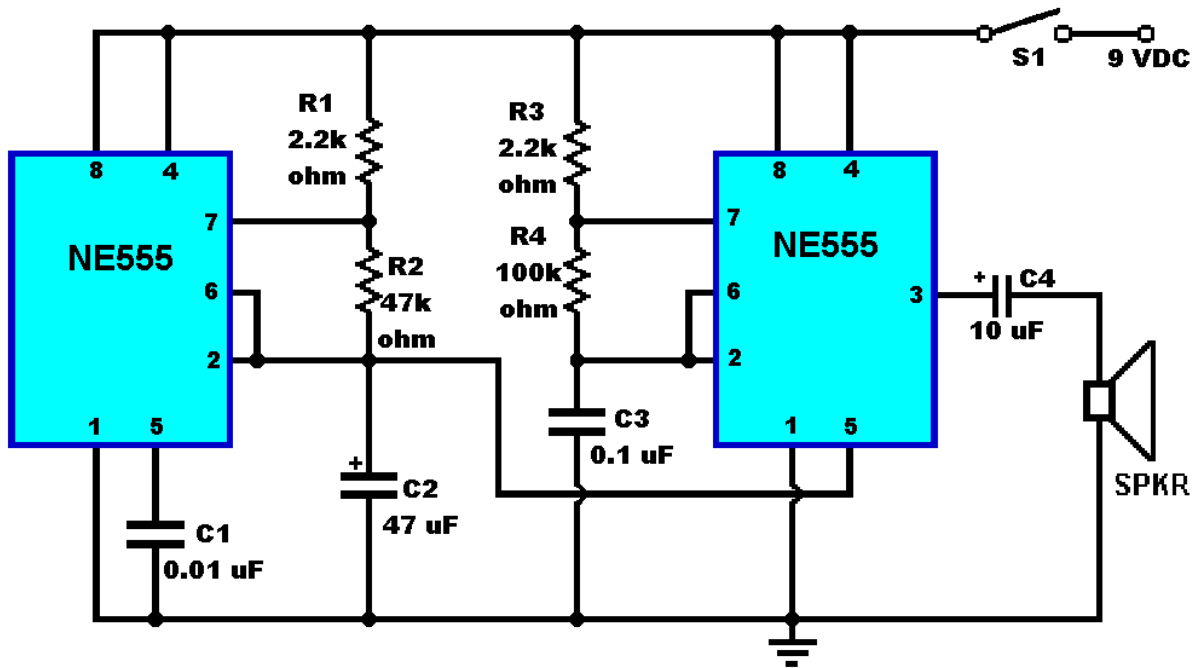

This is a more advance circuit but it is fun to experiment with. The various capacitors and resistors will control the range of the pitch and duration and frequency of the range of the pitch.

Enjoy!